

P40 PRESSURE SWITCH



www.k-dyne.com

702 South Persimmon, Suite 1C
Tomball, TX 77375
P: 281.397.7099
F: 281.397.7495

MODEL P40 PRESSURE SWITCH

The K-Dyne Model P40 Pneumatic Pressure Switch functions as a 3-way "block and bleed" valve that can be configured to respond to increasing or decreasing process pressures. The standard unit utilizes a patented system which provides three piston diameters that are selected by simply changing the orientation of on part. When used in combination with one of three available spring sizes, the Model P40 offers sensing ranges from 10-10,000 psi.

SPECIFICATIONS

Set Point Deviation	±1% max.
Deadband	5% of range max
Switch Type	3-way pneumatic
Instrument Pressure	1500 psi max.
Valve Cv Factor	.050
Ambient Temperature Range	-20/+180° F -29/+82° C

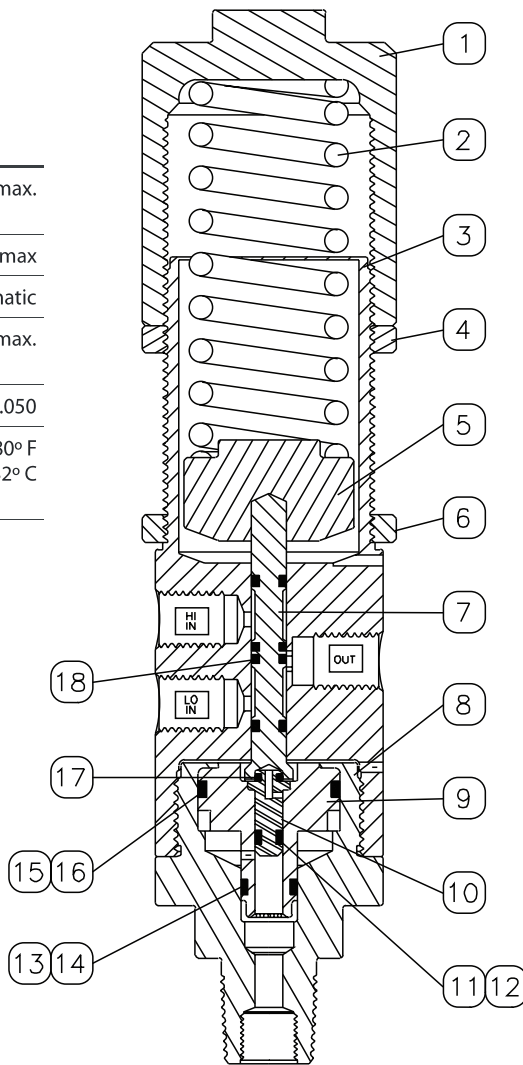

Parts List for P40 Pressure

ITEM NO.	QTY.	DESCRIPTION	MATERIAL	PART NO.
1	1	Spring Cap	Delrin 507	40-005-000
2A	1	Spring (White)	ASTM-401	40-001-000
2B	1	Spring (Blue)	ASTM-401	40-002-000
2C	1	Spring (Red)	ASTM-401	40-003-000
3	1	Body	AISI 316 St. Stl.	40-012-000
4	1	Lock Ring	Delrin 507	40-010-000
5	1	Spring Plate	Delrin 507	40-006-000
6	1	Panel Mount Ring (opt)	Delrin 507	40-010-000
7	1	Spool	AISI 316 St. Stl.	40-004-000
8	1	Base	AISI 316 St. Stl.	40-007-000
9	1	1.25"/.50" Piston (Lg)	AISI 316 St. Stl.	40-008-000
10	1	.25" Piston (Small)	AISI 316 St. St.	40-009-000
11	1	O-Ring .25" Piston	Fluorocarbon	V0-006-75T
12	1	Back Up .25" Piston	PTFE	TB-006-00C
13	1	O-Ring .50" Piston	Fluorocarbon	V0-012-75T
14	1	Back Up .50" Piston	PTFE	TB-012-00C
15	1	O-Ring 1.25" Piston	Fluorocarbon	V0-024-75T
16	1	Back Up 1.25" Piston	PTFE	TB-024-00C
17	1	Friction Seal	Fluorocarbon	V0-006-75H
18	4	Spool Seal	Fluorocarbon	VQ-008-75T
19	---	Repair Kit	Items 11 thru 18	40-013-000

Ordering Number

P40 P 00

STANDARD SERVICE	-40° F TEMP SERVICE	+300° F TEMP SERVICE	+150 PSI SUPPLY	AISI 316 ST. STL	INCONEL 625	MONEL	HASTELLOY C	SPRING CODE (SEE RANGE CHART)	PISTON CODE (SEE RANGE CHART)	FLUOROCARBON PISTON SEALS (STD) --20° -300° F	KALREZ PISTON SEALS --20° -450° F	BUNA PISTON SEALS (NOT FOR H2S) --20° -450° F	NO SPECIAL FEATURES	VENT PORT INDICATOR	VENT SCREEN	PANEL MOUNT	SCALE	OPTION P & S (PANEL MOUNT & SCALE)
—	L	H	P	3	I	M	H			V	K	B	0	1	2	P	S	T

RANGE CHART

Spring Codes Color	AVAILABLE RANGES—PSI (BAR)									
	10-115	20-230	50-450	200-750	500-1500	1000-3000	1000-3000	2000-5000	5000-10000	
Standard Spring										
W (White)	X			X			X			
B (Blue)		X			X			X		
R (Red)			X			X			X	
Piston Diameter	1.25"	1.25"	1.25"	.50"	.50"	.50"	.25"	.25"	.25"	
Piston Code	1	1	1	2	2	2	3	3	3	

- 10,000—20,000 PSI Consult Factory
- 1-9 PSI Consult Factory